

Original article

Generation of the outer membrane potential in mitochondria by the VDAC-glycerol kinase complexes and its possible metabolic role

Generación del potencial de membrana externa en las mitocondrias por los complejos VDAC-glicerol quinasa y su posible papel metabólico

Viktor V. Lemeshko

Grupo de Biofísica, Escuela de Física, Facultad de Ciencias, Universidad Nacional de Colombia, Sede Medellín, Medellín, Colombia

Abstract

Mitochondrial outer membrane plays a crucial role in the regulation of energy metabolism in aerobic cells, controlling the exchange of various charged metabolites and inorganic ions through its voltage-dependent anion channels (VDACs). Several possible mechanisms of generation of the outer membrane potential (OMP) have been proposed. One of them, the VDAC-hexokinase (VDAC-HK) mechanism, explained the Warburg and Crabtree effects as a result of an electrical suppression of mitochondria by the metabolically dependent OMP. This work proposes a new VDAC-glycerol kinase (VDAC-GK) mechanism for OMP generation, taking into account that glycerol kinase competes with hexokinase for the same binding site on VDAC. The computational model developed demonstrated the possibility of OMP generation. The OMP magnitude predicted by the model depends on the intracellular concentrations of glycerol and glycerol-3-phosphate. According to the thermodynamic analysis, a relatively high positive OMP should accelerate the oxidation of external glycerol-3-phosphate by the glycerol-3-phosphate dehydrogenase (GPD2) localized on the outer side of the mitochondrial inner membrane. The possible physiological and pathophysiological roles of generated OMP in cell metabolism regulation through the “electrical crossroad” of lipid metabolism, glycolysis, and oxidative phosphorylation are subjects for future experimental study.

Keywords: VDAC; Glycerol kinase; Glycerol-3-phosphate dehydrogenase, GPD2; Mitochondrial outer membrane; Membrane potential.

Resumen

La membrana mitocondrial externa desempeña un papel crucial en la regulación del metabolismo energético en las células aeróbicas al controlar el intercambio de diversos metabolitos cargados e iones inorgánicos a través de sus canales aniónicos dependientes de voltaje (*voltage-dependent anion channels*, VDAC). Se han propuesto diversos mecanismos para la generación del potencial de membrana externa (OMP). Uno de ellos, el mecanismo VDAC-hexoquinasa (VDAC-HK), permitió explicar los efectos Warburg y Crabtree como resultado de una supresión eléctrica de las mitocondrias por el OMP dependiente del metabolismo. Se propone aquí un nuevo mecanismo, el VDAC-glicerol quinasa (VDAC-GK), para la generación del OMP, considerando que la glicerol quinasa compete con la hexoquinasa por el mismo sitio de unión en los VDAC. El modelo computacional desarrollado demostró la posibilidad de generar el OMP. La magnitud del OMP predicha por el modelo depende de las concentraciones intracelulares de glicerol y glicerol-3-fosfato. Según el análisis termodinámico, un OMP positivo relativamente alto, generado por los complejos VDAC-GK, debería acelerar la oxidación del glicerol-3-fosfato externo por acción de la glicerol-3-fosfato deshidrogenasa (GPD2), localizada en el lado externo de la membrana

Citation: Lemeshko VV. Generation of the outer membrane potential in mitochondria by the VDAC-glycerol kinase complexes and its possible metabolic role. Revista de la Academia Colombiana de Ciencias Exactas, Físicas y Naturales. 2026 April 8. doi: <https://doi.org/10.18257/raccefyn.3491>

Editor: Luis Fernando García

Corresponding autor:

Viktor V. Lemeshko;
vvasilie@unal.edu.co

Received: November 11, 2025

Accepted: January 27, 2026

Published on line: April 8, 2026



This is an open access article distributed under the terms of the Creative Commons Attribution License.

mitocondrial interna. Las posibles funciones fisiológicas y fisiopatológicas del OMP generado en la regulación del metabolismo celular a través de la «encrucijada eléctrica» del metabolismo lipídico, la glucólisis y la fosforilación oxidativa, constituyen temas para futuros estudios experimentales.

Palabras clave: VDAC; Glicerol quinasa; Deshidrogenasa de glicerol-3-fosfato GPD2; Membrana mitocondrial externa; Potencial de membrana.

Introduction

Mitochondrial outer membrane (MOM) plays a crucial role in the regulation of the exchange of negatively charged metabolites and inorganic ions between the mitochondria and the cytoplasm of aerobic cells, mainly through the voltage-dependent anion channels VDAC1, VDAC2, and VDAC3 (Colombini & Mannella, 2012; Lemasters, 2017; Rostovtseva *et al.*, 2021; Lemeshko, 2023). The preferential direct access to the mitochondrial ATP is realized through the interaction of kinases such as creatine kinase or hexokinase, with some VDACs in MOM (Lemeshko, 2023). In the heart, for example, creatine kinase-VDAC (CK-VDAC) complexes are part of the creatine phosphate-creatine shuttle, providing fast transfer of the energy from mitochondria to sarcomeres (Wallimann *et al.*, 2011). In cancer cells, the hexokinase (HK) activity associated with the mitochondrial VDACs is more than two orders of magnitude higher than in normal cells (Arora & Pedersen, 1988; Mathupala *et al.*, 2009). Considering VDAC-HK complexes as a biological battery that generates OMP using the Gibbs free energy of HK reaction, the Warburg type metabolism and Crabtree effect may be explained as consequences of an electrical suppression of mitochondria (Lemeshko, 2021, 2023).

Interestingly, glycerol kinase (GK) is able to compete with HK for the same binding site on VDAC (Adams *et al.*, 1991). Both GK and HK are rate-limiting enzymes in glycerol and glucose metabolism, respectively (Kaneko & Ishibashi, 1985). A relatively high quantity of GK associated with mitochondria has been reported for the brain, for example (Kaneko & Ishibashi, 1985; Ostlund *et al.*, 1983). Glycerol-3-phosphate ($G3P^{2-}$) produced by the GK reaction is oxidized by the glycerol-3-phosphate dehydrogenase (GPD2) localized on the outer surface of the mitochondrial inner membrane (MIM) in some normal tissues (Ostlund *et al.*, 1983; Mráček *et al.*, 2013) and cancers (Mráček *et al.*, 2013; Oh *et al.*, 2023, 2024; Gaertner *et al.*, 2025). If we assume that VDAC-GK complexes in MOM generate positive OMP, as suggested for the VDAC-HK complexes (Lemeshko, 2021, 2023), we may conclude that they can cause a strong electrical control of the $G3P^{2-}$ oxidation rate in mitochondria, which is known as an important lipid crossroad of metabolism, glycolysis, and oxidative phosphorylation (Mráček *et al.*, 2013; Oh *et al.*, 2023, 2024; Gaertner *et al.*, 2025).

Here, I propose the mechanism of VDAC-GK-dependent generation of OMP (Figure 1) and estimate its possible magnitudes using a computational model. Based on the thermodynamic analysis performed, the model demonstrated that OMP generated under physiological concentrations of glycerol and $G3P^{2-}$ depends on the occupancy of mitochondrial VDACs by GK, on the voltage-gating properties of free VDACs (non-bound to GK), and the quantity of voltage-insensitive VDAC3 in MOM. According to the estimations, the generated positive OMP should strongly accelerate the $G3P^{2-}$ mitochondrial oxidation rate.

In general, OMP generation by the VDAC-GK, VDAC-HK, and CK-VDAC complexes may play a crucial physiological role in the crossroad of lipid metabolism, glycolysis, and oxidative phosphorylation. Such a new “electrical crossroad” in the regulation of cell energy metabolism under physiological and pathophysiological conditions seems interesting for further experimental study.

Materials and methods

Computational model of VDAC-glycerol kinase-dependent generation of OMP

Mitochondrial outer membrane contains various VDAC isoforms (Figure 1), some of which (VDAC1) form VDAC1-GK complexes. The total conductance of all VDACs in their open state (gT) was equated to 100 arbitrary units (a.u.). This total conductance (gT)

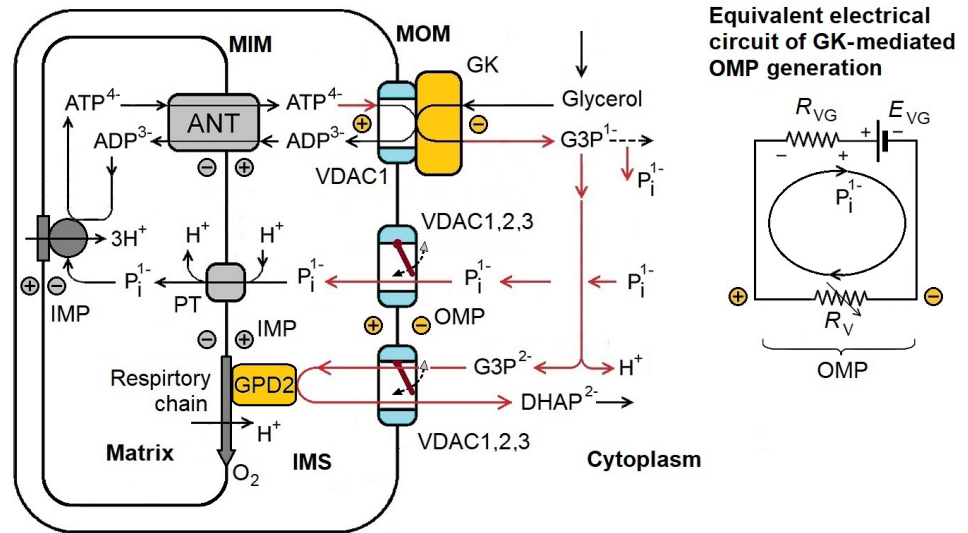

Figure 1. Possible mechanism of the VDAC1-GK-dependent generation of OMP and the electrical potentiation of G3P²⁻ oxidation in mitochondria. According to the equivalent electrical circuit, OMP is a voltage drop on the R_v resistance of free VDACS in MOM. The E_{VG} voltage of the VDAC1-GK battery depends on the Gibbs free energy of the GK reaction; the internal R_{VG} resistance of this battery depends on the quantity of VDAC1-GK complexes in MOM, and is lower at larger quantities of these complexes.

included the N_{VG} conductance of the VDAC1 fraction forming VDAC1-GK complexes, the N_{vs} conductance of the remaining VDAC1 fraction, and the VDAC2 fraction, as well as the N_{ns} conductance of the VDAC3 voltage-insensitive fraction (**Figure 1**):

$$N_{VG} + N_{vs} + N_{ns} = gT \quad (1)$$

The N_{ns} fraction was taken at gT 10%, although some estimations were also performed at 5%, 15%, and 20%. The N_{VG} fraction was taken at 4% for most estimations, but also at 3.5% and 3.0%.

The total MOM conductance (permeability) gV_p for P_i^{1-} and $G3P^{2-}$ through the free VDAC1 and VDAC2 N_{vs} fraction, non-bound to GK, and the VDAC3 N_{ns} fraction (**Figure 1**) was expressed in a.u. by a bell-shaped function of OMP (**Figure 2**):

$$gV_p = N_{ns} + N_{vs} \cdot [g_c + (1 - g_c) \cdot \exp(-S \cdot OMP^2)], \quad (2)$$

where g_c is the relative conductance of electrically closed VDAC1 and VDAC2, S is their voltage-gating sensitivity, taken at $S=0.04 \text{ mV}^{-1}$, $S=0.035 \text{ mV}^{-1}$, and $S=0 \text{ mV}^{-1}$. OMP is expressed in mV.

The functioning of the VDAC1-GK complexes in MOM may be considered as a biological battery that uses the Gibbs free energy of the GK reaction to move the negatively charged P_i^{1-} across MOM from ATP⁴⁻ in MIM to glycerol in the cytoplasm, thus generating positive OMP. The voltage E_{VG} of this battery (**Figure 1**) is:

$$E_{VG} = - \left(\frac{\Delta G_{GK}^{\circ}}{F} + \frac{RT}{F} \ln \frac{[G3P]_o}{([ATP]_i/[ADP]_i) \cdot [G]_o} \right), \quad (3)$$

where $\Delta G_{GK}^{\circ} = -21.3 \text{ kJ/mol}$ is the standard Gibbs free energy of GK reaction, F is the Faraday constant, R is the universal gas constant, and $T = 310 \text{ K}$. $[ATP]_i$ and $[ADP]_i$ are concentrations of ATP⁴⁻ and ADP³⁻, respectively, in the mitochondrial intermembrane space (IMS). The ratio $[ATP]_i/[ADP]_i$ in IMS was taken at 200 for all estimations. $[G]_o$ is the concentration of glycerol and $[G3P]_o$ that of glycerol-3-phosphate in the cytoplasm.

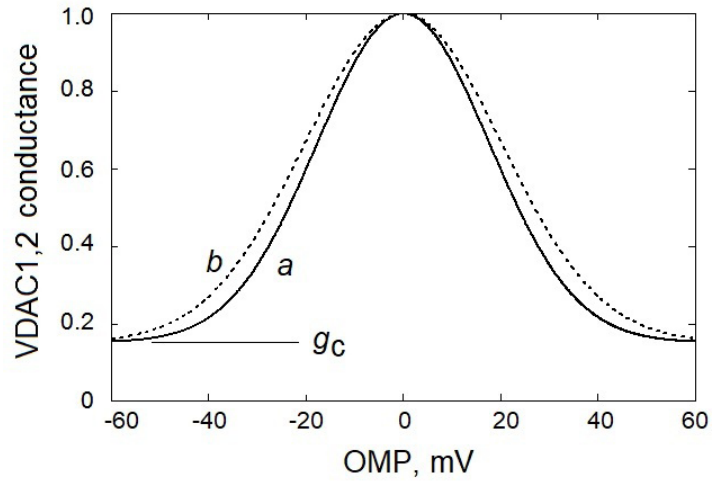

Figure 2. The voltage-gating properties of VDAC1 and VDAC2 in MOM were used at (a) a voltage-gating sensitivity of $S=0.04 \text{ mV}^{-1}$, and (b) of $S=0.035 \text{ mV}^{-1}$. g_c : relative conductance of electrically closed VDACS (eq. 2)

The gVG conductance of the VDAC1-GK complexes (N_{VG} fraction) for P_i^{1-} depends on the activity of GK bound to VDAC1:

$$gVG = \frac{v_{m,VG} \cdot N_{VG} \cdot [G]_o}{K_{m,G} + [G]_o}. \quad (4)$$

Here, $v_{m,VG} \cdot N_{VG}$ is the maximum GK activity of MOM (P_i^{1-} conductance of the VDAC1-GK complexes), where $v_{m,VG}=1.0$ for the control. To estimate an 80% effect of inhibition of this activity, it was taken that $v_{m,VG}=0.2$. The Michaelis–Menten constant was taken at $K_{m,G} = 4 \text{ } \mu\text{M}$ glycerol (Seltzer & McCabe, 1984). $[G]_o$ is the concentration of glycerol in the cytoplasm.

The circulation of P_i^{1-} across MOM may be presented as an electrical current I_p (Figure 1). According to Ohm's law, the voltage E_{VG} (eq. 3) of the VDAC1-GK battery is the sum of OMP and the voltage drop on the internal resistance $R_{VG}=1/gVG$ of the VDAC1-GK battery:

$$E_{VG} = OMP + \frac{I_p}{gVG}. \quad (5)$$

OMP is the voltage drop on the resistance $R_v=1/gV_p$ of all free VDACS in MOM non-bound to GK (Figure 1):

$$OMP = \frac{I_p}{gV_p}. \quad (6)$$

The system of equations 1-6 allowed the estimation of generated OMP as a function of glycerol and glycerol-3-phosphate concentrations, depending on the VDACS characteristics in MOM mentioned above. It was assumed that the steady state electroneutral exchange $G3P^{2-}/DHAP^{2-}$ across MOM (Figure 1) did not influence OMP generation.

OMP-dependent oxidation of glycerol-3-phosphate in mitochondria

The $G3P^{2-}$ oxidation rate in mitochondria with GPD2 localized on the other side of MIM should depend on the OMP that influences $G3P^{2-}$ concentration in IMS (Figure 1). Let us represent GPD2 activity as the rate of a unidirectional reaction:

$$v = \frac{v_m \cdot [G3P]_i}{K_{m,GP} + [G3P]_i} \quad (7)$$

where $[G3P]_i$ is the concentration of $G3P^{2-}$ in IMS, v_m is the maximum GPD2 activity taken at 100 a.u., and $K_{m,GP}$ is the Michaelis-Menten constant taken at 1 mM (Beleznai *et al.*, 1988) or 18 mM (Patole *et al.*, 1986).

According to the Goldman equation, the J_{G3P} of $G3P^{2-}$ flux across MOM depends on OMP and $G3P^{2-}$ concentrations in the cytoplasm ($[G3P]_o$) and IMS ($[G3P]_i$):

$$J_{G3P} = -gV_p \cdot \frac{n \cdot F \cdot OMP}{R \cdot T} \frac{[G3P]_i - [G3P]_o \cdot \exp\left(\frac{-n \cdot F \cdot OMP}{R \cdot T}\right)}{1 - \exp\left(\frac{-n \cdot F \cdot OMP}{R \cdot T}\right)}, \quad (8)$$

where F is the Faraday constant, R is the gas constant, and $T = 310$ K, $n = -2$ is the $G3P^{2-}$ valence.

In a steady state, the v rate (eq. 7) should be equal to J_{G3P} (eq. 8):

$$v = J_{G3P}. \quad (9)$$

The system of eqs. 1,2,7-9 was solved assuming the total conductance: $gT=100$ a.u., $N_{VG}=4\%$ of gT , and $N_{ns}=10\%$ of gT (eqs. 1,2). OMP for these estimations was changed in a range of -50 mV to +50 mV.

VDAC-glycerol kinase-mediated electrical modulation of glycerol-3-phosphate oxidation rate in mitochondria

In this section, the $G3P^{2-}$ oxidation rate in mitochondria was calculated using the full system of eqs. 1-9 as a function of OMP generated by the VDAC1-GK complexes in MOM at various glycerol and $G3P^{2-}$ concentrations for the VDACs characteristics in MOM indicated in figure legends.

All calculations were performed by numerical methods using the licensed software Mathcad Professional 2001i (MathSoft, Cambridge, MA).

Results

The OMP estimations generated by the VDAC1-GK complexes of MOM (eqs. 1-6) are shown in **Figure 3** as functions of glycerol at a fixed concentration of $G3P^{2-}=0.5$ mM. The data indicated that OMP magnitude strongly decreased when the quantity of VDAC1-GK complexes in MOM decreased from $N_{VG}=4\%$ (**Figure 3A**) to $N_{VG}=3.5\%$ (**Figure 3C**) and to $N_{VG}=3\%$ (**Figure 3D**) at the VDAC's voltage-gating sensitivity parameter of $S=0.04$ mV⁻¹. Additionally, a remarkable decrease in OMP (**Figure 3**) was revealed when the percentage of permanently open VDAC3 (N_{ns}) increased. All these were predicted even for the range of relatively low glycerol concentrations.

The effect of a decrease in the voltage-gating sensitivity of free VDAC1,2 from $S=0.04$ mV⁻¹ (**Figure 3A**) to $S=0.035$ mV⁻¹ (**Figure 3B**) at the same $N_{VG}=4\%$ is essentially similar to that revealed by the quantity of the VDAC1-GK complexes N_{VG} decreasing from 4% (**Figure 3A**) to 3.5% (**Figure 3C**) at $S=0.04$ mV⁻¹. On the other hand, very low magnitudes of OMP with no abrupt rise parallel to glycerol concentration increase were seen for $S=0$ mV⁻¹, even for the case of relatively low VDAC3 quantity at $N_{ns}=10\%$ (**Figure 3A**).

When positive inside, OMP should increase the rate of $G3P^{2-}$ oxidation in mitochondria (**Figure 1**) according to the data shown in **Figure 4** for the cases of $K_{m,GP}=1$ mM $G3P^{2-}$ (**Figure 4A**) and $K_{m,GP}=18$ mM $G3P^{2-}$ (**Figure 4B**) of mitochondrial GPD2 (eq. 7). OMP-dependent increase in the $G3P^{2-}$ oxidation rate, most pronounced at $G3P^{2-}$ low concentrations, may be attributed to a significant decrease of apparent $K_{m,GP}$. At OMP=+30 mV, for example, $K_{m,GP}$ decreased from 1 mM to an apparent $K_{m,GP}$ of approximately 0.1 mM (**Figure 4A**), or from 18 mM to approximately 1.8 mM (**Figure 4B**). This apparent decrease in $K_{m,GP}$ answers to the OMP-dependent capture of cytoplasmic $G3P^{2-}$ into IMS, which thus increases its concentration near GPD2 (**Figure 1**).

OMP generated by the mitochondria VDAC1-GK complexes (at $N_{VG}=4\%$) was calculated as a function of glycerol and $G3P^{2-}$ concentrations in the cytoplasm (**Figure 5**). The corresponding impact of this OMP on the rate of mitochondrial oxidation of $G3P^{2-}$ for

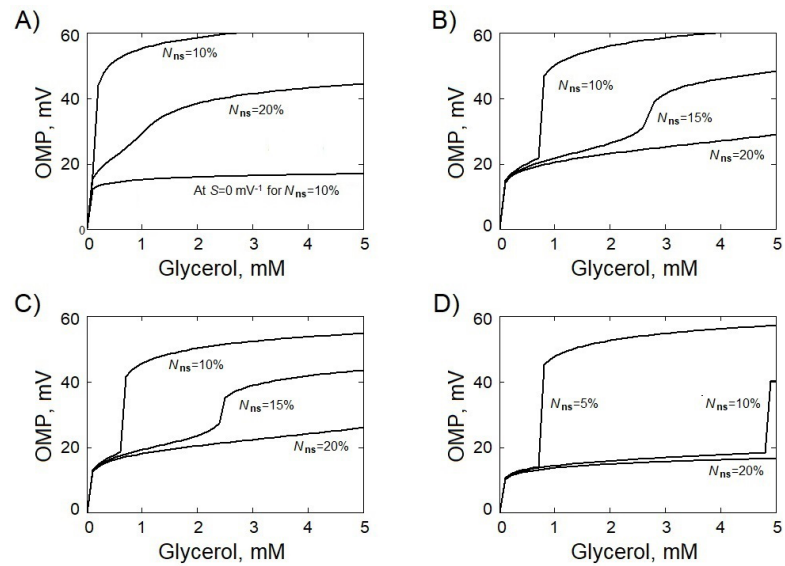

Figure 3. Glycerol-dependent generation of OMP by the VDAC1-GK complexes of MOM (eqs. 1-6) at $N_{VG}=4\%$ (A, B), $N_{VG}=3.5\%$ (C), $N_{VG}=3\%$ of gT (D) (eq. 1), and at various quantities of the voltage-insensitive VDAC3 in MOM (N_{ns}). A, C, D: at VDAC's voltage-gating sensitivity of $S=0.04 \text{ mV}^{-1}$ and, only in A, also at $S=0 \text{ mV}^{-1}$ for $N_{ns}=10\%$; B: at $S=0.035 \text{ mV}^{-1}$. Cytoplasmic concentration of $G3P^{2-}=0.5 \text{ mM}$, $K_{m,G}=4 \text{ }\mu\text{M}$ glycerol, and $v_{m,VG}=1.0$ (eq. 4)

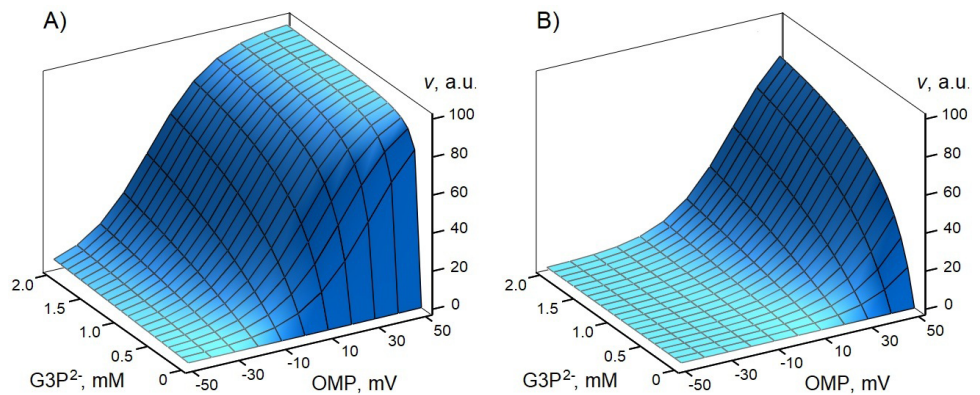

Figure 4. Influence of OMP on the rate of $G3P^{2-}$ oxidation in mitochondria (eqs. 1,2,7-9). A: at $K_{m,GP}=1 \text{ mM}$; B: at $K_{m,GP}=18 \text{ mM}$ (eq. 7). $gT=100 \text{ a.u.}$, $N_{VG}=4\%$, $N_{ns}=10\%$ (eq. 1), and $S=0.04 \text{ mV}^{-1}$. “ $G3P^{2-}$, mM” is $[G3P]_0$ in eq. 8.

$K_{m,GP}=1 \text{ mM}$ $G3P^{2-}$ was also estimated (Figure 5A and C, respectively) and for $K_{m,GP}=18 \text{ mM}$ $G3P^{2-}$ (Figure 5B and D, respectively). The full system of eqs. 1-9 was used for such estimations, showing equal results for OMP generated at $K_{m,GP}=1 \text{ mM}$ $G3P^{2-}$ and $K_{m,GP}=18 \text{ mM}$ $G3P^{2-}$ (Figure 5A and C, respectively), because OMP generation does not depend on the $G3P^{2-}$ oxidation that produces dihydroxy acetone phosphate ($DHAP^{2-}$) of the same valence (Figure 1). At the critical increasing glycerol concentrations and the critical $G3P^{2-}$ decreasing concentration, OMP strongly increased, abruptly switching the rates of mitochondrial oxidation of cytoplasmic $G3P^{2-}$ to significantly higher levels (Figure 5B and D). The prediction was that this would be most pronounced for the case of $K_{m,GP}=18 \text{ mM}$ (Figure 5D).

The computational model also demonstrated that the critical concentrations of glycerol for an abrupt increase in the OMP generated at lower VDAC1,2 voltage-gating sensitivity ($S=0.035 \text{ mV}^{-1}$) shifted to significantly higher concentrations at any given G3P^{2-} concentration, thus causing a remarkable abrupt increase in the rate of mitochondrial oxidation of cytoplasmic G3P^{2-} (**Figure 6A and B**, respectively).

Very low magnitudes of OMP with no abrupt increase were predicted when the maximum activity of the VDAC1-attached GK was reduced from $v_{m,VG}=1$ to $v_{m,VG}=0.2$ (eq. 4), as it would be at an 80% restriction of the conductance gVG of the VDAC1-GK complexes for P_i^{1-} (eq. 3) by GK attached to the VDAC1 N_{VG} fraction. That explained why a several-fold increase in the quantity of the VDAC1-GK complexes, from $N_{VG}=4\%$ to $N_{VG}=16\%$, was needed to reveal an abrupt glycerol concentration-dependent increase in OMP and in the mitochondrial G3P^{2-} oxidation rate (**Figure 6C and D**, respectively), compared with the corresponding results obtained at $v_{m,VG}=1$ (**Figure 5C and D**, respectively).

These results, based on the thermodynamic estimations, demonstrated a high probability of glycerol-dependent generation of OMP by the VDAC-GK complexes in MOM and a strong electrical acceleration of the G3P^{2-} oxidation rate in mitochondria containing GPD2.

Discussion

Glycerol kinase transforms glycerol into glycerol-3-phosphate, which is also the product of glycolysis. Glycerol-3-phosphate is oxidized in mitochondria containing GPD2, thus providing a direct link of lipid metabolism and glycolysis to the oxidative phosphorylation system through the glycerol-3-phosphate shuttle (**Ostlund et al.**, 1983; **Mráček et al.**,

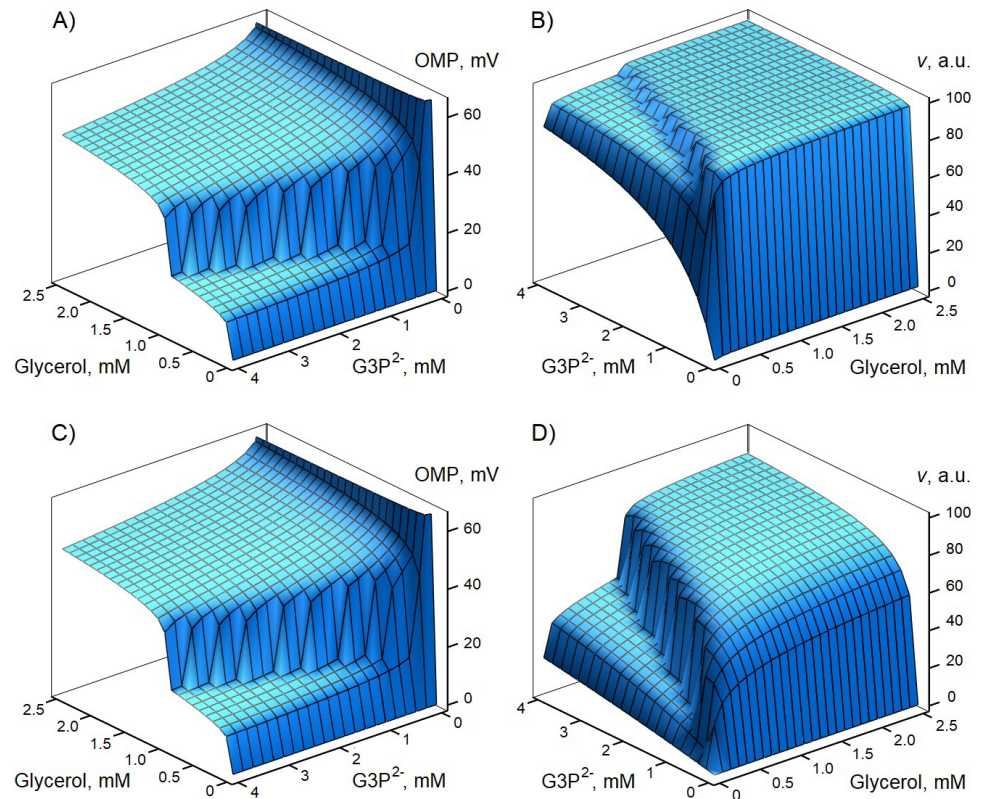

Figure 5. Glycerol-dependent generation of OMP by the VDAC1-GK complexes (**A,C**), and the electrical, OMP-dependent modulation of the rate of G3P^{2-} oxidation in mitochondria (**B, D**) (eqs. 1-9). **A, B:** at $K_{m,GP}=1 \text{ mM}$ G3P^{2-} ; **C, D:** at $K_{m,GP}=18 \text{ mM}$ G3P^{2-} (eq. 7); $S=0.04 \text{ mV}^{-1}$. $gT=100 \text{ a.u.}$, $N_{VG}=4\%$, $N_{ns}=10\%$ (eq. 1), $K_{m,G}=4 \text{ }\mu\text{M}$ glycerol and $v_{m,VG}=1.0$ (eq. 4)

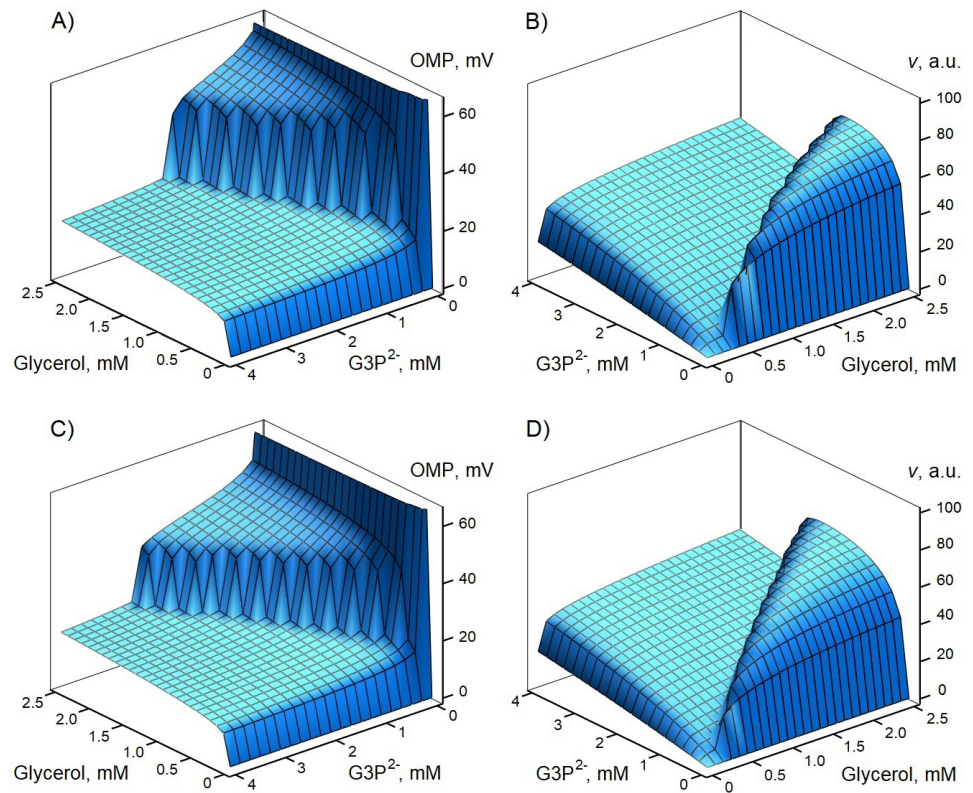

Figure 6. Glycerol-dependent generation of OMP by the VDAC1-GK complexes (**A, C**) and OMP-dependent modulation of the rate of G3P²⁻ oxidation in mitochondria (**B, D**) (eqs. 1-9) at a decreased VDAC voltage-gating sensitivity, $S=0.035 \text{ mV}^{-1}$ (**A, B**), and decreased GK activity (**C, D**): **A, B:** at $S=0.035 \text{ mV}^{-1}$, $gT=100 \text{ a.u.}$, $N_{VG}=4\%$, and $v_{m,VG}=1.0$. **C, D:** at $S=0.04 \text{ mV}^{-1}$, $gT=100 \text{ a.u.}$, $N_{VG}=16\%$ and $v_{m,VG}=0.2$ (eq. 4); $K_{m,GP}=18 \text{ mM}$ G3P²⁻, $K_{m,G}=4 \text{ }\mu\text{M}$ glycerol, and $N_{ns}=10\%$ (eq. 1)

2013; *Oh et al.*, 2023, 2024; *Gaertner et al.*, 2025). Alterations of this shuttle have been implicated in thermogenesis, cell growth, and several pathologies (*Adams et al.*, 1991; *Mráček et al.*, 2013; *Oh et al.*, 2023, 2024; *Gaertner et al.*, 2025).

Glycerol kinase associated with MOM VDACs in the mitochondria of some tissues might function as a biological battery, using its Gibbs' free energy for the generation of OMP (**Figure 1**). This idea is based on the thermodynamic estimations showing the possibility of generation of relatively high positive OMP, depending on the glycerol concentration at a given quantity of G3P²⁻ (**Figure 3**), the occupancy of mitochondrial VDACs with GK (**Figure 3A, C, D**), the quantity of voltage-insensitive VDAC3 in MOM (**Figure 3**), and the voltage-gating sensitivity of VDAC1,2 (**Figure 3A, B**). These data allow the assumption that 10–40 mV OMP, sufficiently high to modulate MOM permeability (**Figure 2**), might be generated by the VDAC-GK complexes in the range of physiological concentrations of glycerol and G3P²⁻.

Interestingly, according to a recent short communication, the possibility of the VDAC-HK-dependent generation of relatively high mitochondrial OMP, hypothesized earlier (*Lemeshko*, 2014), has been confirmed in experiments with HeLa cells (*Abrantes et al.*, 2024). On the other hand, the magnitude of the plasma membrane potential in many tumors has been reported to be significantly diminished (*Yang & Brackenbury*, 2013; *Yu et al.*, 2017). Both the decreased negative plasma membrane potential and the highly positive OMP generated should lead to a more pronounced accumulation of membrane-permeable lipophilic anions in IMS of mitochondria in cancer cells than in normal cells. If such a

lipophilic anion can cause mitochondrial dysfunction, it might be selectively toxic for cancer cells at certain concentrations without significant damage to normal cells, although some toxicity may yet be revealed for the heart and brain, for which relatively high positive OMP has also been predicted (Lemeshko, 2018, 2021). In this respect, the lipophilic anionic flavonoid morin, which has the capacity to uncouple oxidative phosphorylation and inhibit the mitochondrial respiratory chain and ATP/ADP exchange (Nanami *et al.*, 2025), has been shown to suppress the progression of colorectal cancer (Li *et al.*, 2025).

The new, very important effect of OMP might consist in the modulation of the $G3P^{2-}$ mitochondrial oxidation rate produced in the cytoplasm and/or by the mitochondrial VDAC-GK complexes. Estimations of a possible influence of generated OMP on the rate of mitochondrial oxidation of cytoplasmic $G3P^{2-}$, performed for $K_{m,GP}=1$ mM and $K_{m,GP}=18$ mM of GPD2 (eq. 7), predict that the positive OMP should strongly accelerate $G3P^{2-}$ oxidation (Fig. 4), by decreasing an apparent $K_{m,GP}$.

The activity of GPD2, which is the rate-limiting step of the $G3P$ shuttle, is elevated in many cancers and has been considered as a factor increasing the growth of various human tumors (Oh *et al.*, 2023, 2024; Lu *et al.*, 2020). In this respect, recent experimental work has suggested that glycerol, even in the amounts possibly derived from some foods and beverages, might promote the growth of prostate cancer (DeGuzman *et al.*, 2022).

According to the estimations in this study (Figure 5), mitochondrial oxidation of $G3P^{2-}$ may be strongly activated by the positive OMP generated by the VDAC-GK complexes in MOM. Such a VDAC-GK-mediated electrical acceleration of the $G3P$ shuttle might contribute to the growth of human tumors and to the promoting effect of glycerol on the growth of prostate cancer already mentioned.

Even a relatively small change in the VDAC voltage-gating sensitivity might strongly influence this effect (Figure 6A, B). NADH, for example, is one of the natural modulators of the VDAC voltage-gating properties (Lee *et al.*, 1996). A several-fold decrease in the maximum activity of GK attached to VDAC1 requires an almost proportional increase in the quantity of the VDAC-GK complexes in MOM to recover glycerol-dependent generation of high OMP (Figure 6C, D). Thus, the thermodynamic estimations performed (Figures 5 and 6) demonstrated the possibility of a VDAC-GK-dependent generation of a relatively high positive OMP and a remarkable activation by this potential of the rate of mitochondrial oxidation of cytoplasmic $G3P^{2-}$.

On the other hand, a strong inhibition of the $G3P^{2-}$ oxidation in *Saccharomyces cerevisiae* mitochondria has been reported at high NADH concentrations oxidizing NADH dehydrogenase on the outer side of the MIM (Påhlman *et al.*, 2002; Bunoust *et al.*, 2005). These experimental data were interpreted as a result of $G3P^{2-}$ electrons and NADH dehydrogenases competing to enter the respiratory chain, but only for the case of the respiration rate monitoring (Bunoust *et al.*, 2005). No competition was observed using ferricyanide (Fe^{3+}) as a final acceptor of electrons, which was converted into ferrocyanide (Fe^{4+}) (Bunoust *et al.*, 2005).

I would propose an alternative explanation of these experimental data based on my previously published model of NADH-dependent generation of the negative OMP in mitochondria of *S. cerevisiae* of up to -35 mV as a result of a steady state $NADH^{2-}/NAD^1$ exchange across MOM (Lemeshko, 2017). The negative OMP generated by the oxidation of external NADH should strongly decrease $G3P^{2-}$ concentration in MIM and, consequently, the rate of its oxidation. Additionally, NADH should increase VDAC's voltage-gating sensitivity (Lee *et al.*, 1996), favoring OMP generation. The negative OMP might be canceled by a simultaneous steady state Fe^{3+}/Fe^{4+} exchange across MOM, thus preventing inhibition of mitochondria oxidation of $G3P^{2-}$ by the oxidation of NADH as reported in Påhlman *et al.* (2002) and Bunoust *et al.* (2005). Finally, the experimental data interpreted as a competition of electrons to enter the respiratory chain from $G3P^{2-}$ and NADH dehydrogenases (Bunoust *et al.*, 2005) can be explained as an OMP-dependent electrical competition between these negatively charged metabolites to enter the IMS of mitochondria.

Overall, the G3P²⁻ mitochondrial oxidation dependent on OMP generated by the VDAC-GK complexes (**Figures 5 and 6**) or/and by the VDAC-HK and CK-VDAC complexes (**Lemeshko, 2014, 2018, 2021, 2023**), or even by the direct oxidation of external NADH (**Lemeshko, 2017**), may represent a new “electrical crossroad” of lipid metabolism, glycolysis, and the oxidative phosphorylation system. This opens a new field of experimental study of a possible OMP-dependent regulation of cell metabolism under normal and pathophysiological conditions.

Conclusions

The thermodynamic analysis of the proposed VDAC-GK mechanism of OMP generation in mitochondria demonstrated a strong dependence of OMP on the quantity of the VDAC-GK complexes in MOM, their maximum GK activity, the glycerol concentrations, and G3P²⁻ in the cytoplasm, and the voltage-gating properties of free VDACS in MOM. According to the computational model, the positive OMP generated by the VDAC-GK complexes, or by other mechanisms (**Lemeshko, 2023**), should strongly activate mitochondrial oxidation of G3P²⁻, known as the crossroad of lipid metabolism, glycolysis, and the oxidative phosphorylation system. Such a new, “electrical crossroad” in the regulation of cell metabolism is interesting for future experimental studies under various physiological and pathophysiological conditions.

Conflicts of interest

The author declares that he has no competing financial interests or personal relationships that could have influenced the work reported in this paper.

References

- Abrantes, K., Bezrukov, S.M., Rostovtseva, T.K., Rajendran, M.** (2024). Measuring the mitochondrial outer membrane potential in live cells. *Biophysical Journal*, 123(3 Suppl 1), 523A. <https://doi.org/10.1016/j.bpj.2023.11.3165>
- Adams, V., Griffin, L., Towbin, J., Gelb, B., Worley, K., McCabe, E.R.** (1991). Porin interaction with hexokinase and glycerol kinase: metabolic microcompartmentation at the outer mitochondrial membrane. *Biochemical Medicine and Metabolic Biology*, 45(3), 271-291. [https://doi.org/10.1016/0885-4505\(91\)90032-g](https://doi.org/10.1016/0885-4505(91)90032-g)
- Arora, K.K. & Pedersen, P.L.** (1988). Functional significance of mitochondrial bound hexokinase in tumor cell metabolism. Evidence for preferential phosphorylation of glucose by intramitochondrially generated ATP. *Journal of Biological Chemistry*, 263, 17422-17428 (PubMed: 3182854)
- Beleznai, Z., Szalay, L., Jancsik, V.** (1988). Ca²⁺ and Mg²⁺ as modulators of mitochondrial L-glycerol-3-phosphate dehydrogenase. *European Journal of Biochemistry*, 170(3), 631-636. <https://doi.org/10.1111/j.1432-1033.1988.tb13744.x>
- Bunoust, O., Devin, A., Avéret, N., Camougrand, N., Rigoulet, M.** (2005). Competition of electrons to enter the respiratory chain: a new regulatory mechanism of oxidative metabolism in *Saccharomyces cerevisiae*. *Journal of Biological Chemistry*, 280(5), 3407-3413. <https://doi.org/10.1074/jbc.M407746200>
- Colombini, M. & Mannella, C.A.** (2012). VDAC, the early days. *Biochimica et Biophysica Acta – Biomembranes*, 1818(6), 1438-1443. <https://doi.org/10.1016/j.bbmem.2011.11.014>
- DeGuzman, A., Lorensen, M.Y., Walker, A.M.** (2022). Bittersweet: relevant amounts of the common sweet food additive, glycerol, accelerate the growth of PC3 human prostate cancer xenografts. *BMC Research Notes*, 15(1), 101. <https://doi.org/10.1186/s13104-022-05990-9>
- Gaertner, K., Terzioglu, M., Michell, C., Tapanainen, R., Pohjoismäki, J., Dufour, E., Saari, S.** (2025). Species differences in glycerol-3-phosphate metabolism reveals trade-offs between metabolic adaptations and cell proliferation. *Biochimica et Biophysica Acta – Bioenergetics*, 1866(2), 149530. <https://doi.org/10.1016/j.bbabi.2024.149530>
- Kaneko, M. & Ishibashi, S.** (1985). Changes during development in the activities and intracellular locations of glycerol kinase and hexokinase in rat brain and liver: (brain/liver/enzyme localization/glycerol kinase/hexokinase). *Development Growth and Differentiation*, 27(6), 745-749. <https://doi.org/10.1111/j.1440-169X.1985.00745.x>

- Lee, A.C., Xu, X., Colombini, M.** (1996). The role of pyridine dinucleotides in regulating the permeability of the mitochondrial outer membrane. *Journal of Biological Chemistry*, 271(43), 26724-26731. <https://doi.org/10.1074/jbc.271.43.26724>
- Lemasters, J.J.** (2017). Evolution of voltage-dependent anion channel function: from molecular sieve to governor to actuator of ferroptosis. *Frontiers in Oncology*, 7, 303. <https://doi.org/10.3389/fonc.2017.00303>
- Lemeshko, V.V.** (2014). VDAC electronics: 1. VDAC-hexo(glucokinase) generator of the mitochondrial outer membrane potential. *Biochimica et Biophysica Acta – Biomembranes*, 1838, 1362-1371. <https://doi.org/10.1016/j.bbamem.2014.01.001>
- Lemeshko, V.V.** (2017). VDAC electronics: 4. Novel electrical mechanism and thermodynamic estimations of glucose repression of yeast respiration. *Biochimica et Biophysica Acta – Biomembranes*, 1859(11), 2213–2223. <https://doi.org/10.1016/j.bbamem.2017.09.001>
- Lemeshko, V.V.** (2018). VDAC electronics: 5. Mechanism and computational model of hexokinase-dependent generation of the outer membrane potential in brain mitochondria. *Biochimica et Biophysica Acta – Biomembranes*, 1860(12), 2599-2607. <https://doi.org/10.1016/j.bbamem.2018.10.004>
- Lemeshko, V.V.** (2021). Electrical control of the cell energy metabolism at the level of mitochondrial outer membrane. *Biochimica et Biophysica Acta – Biomembranes*, 1863(1), 183493. <https://doi.org/10.1016/j.bbamem.2020.183493>
- Lemeshko, V.V.** (2023). VDAC as a voltage-dependent mitochondrial gatekeeper under physiological conditions. *Biochimica et Biophysica Acta – Biomembranes*, 1865(6), 184175. <https://doi.org/10.1016/j.bbamem.2023.184175>
- Li, R., Wang, F., Huang, L., Zhao, L., Qin, T., Liu, S., Xu, K., Wang, B., Li, L., He, S.** (2025). Morin inhibits the progression of 5-fluorouracil-resistant colorectal cancer by suppressing autophagy. *International Journal of Biochemistry and Cell Biology*, 185, 106783. <https://doi.org/10.1016/j.biocel.2025.106783>
- Lu, J., Xu, Z., Duan, H., Ji, H., Zhen, Z., Li, B., Wang, H., Tang, H., Zhou, J., Guo, T., Wu, B., Wang, D., Liu, Y., Niu, Y., Zhang, R.** (2020). Tumor-associated macrophage interleukin- β promotes glycerol-3-phosphate dehydrogenase activation, glycolysis and tumorigenesis in glioma cells. *Cancer Science*, 111(6), 1979-1990. <https://doi.org/10.1111/cas.14408>
- Mathupala, S.P., Ko, Y.H., Pedersen, P.L.** (2009). Hexokinase-2 bound to mitochondria: cancer's stygian link to the “Warburg effect” and a pivotal target for effective therapy. *Seminars in Cancer Biology* 19, 17-24. <https://doi.org/10.1016/j.semcancer.2008.11.006>
- Mráček, T., Drahotka, Z., Houštěk, J.** (2013). The function and the role of the mitochondrial glycerol-3-phosphate dehydrogenase in mammalian tissues. *Biochimica et Biophysica Acta – Bioenergetics*, 1827(3), 401-410. <https://doi.org/10.1016/j.bbabi.2012.11.014>
- Nanami, L.F., Klosowski, E.M., Mito, M.S., Machado Esquissato, G.N., Viana, G.A., Oliveira Abido, A.C., da Silva, M.C., da Silva Mendonça, A.P., Romano de Melo, G.S., Alves Bueno, P.S., Garcia, F.P., Bidoia, D.L., Nakamura, T.U., Nakamura, C.V., Ishii-Iwamoto, E.L., Ferro, A.P., Dos Santos, W.D., Ferrarese-Filho, O., Marchiosi, R., Constantin, R.P.** (2025). Morin as a modulator of hepatic glucose fluxes: A balance between antihyperglycemic potential and mitochondrial toxicity. *Journal of Biochemical and Molecular Toxicology*, 39(7), e70386. <https://doi.org/10.1002/jbt.70386>
- Oh, S., Jo, S., Bajzikova, M., Kim, H.S., Dao, T.T.P., Rohlena, J., Kim, J.M., Neuzil, J., Park, S.** (2023). Non-bioenergetic roles of mitochondrial GPD2 promote tumor progression. *Theranostics* 13(2), 438-457. <https://doi.org/10.7150/thno.75973>
- Oh, S., Mai, X.L., Kim, J., de Guzman, A.C.V., Lee, J.Y., Park, S.** (2024). Glycerol 3-phosphate dehydrogenases (1 and 2) in cancer and other diseases. *Experimental and Molecular Medicine*, 56(5), 1066-1079. <https://doi.org/10.1038/s12276-024-01222-1>
- Ostlund, A.K., Göhring, U., Krause, J., Brdiczka, D.** (1983). The binding of glycerol kinase to the outer membrane of rat liver mitochondria: its importance in metabolic regulation. *Biochemical Medicine*, 30(2), 231-245. [https://doi.org/10.1016/0006-2944\(83\)90089-3](https://doi.org/10.1016/0006-2944(83)90089-3)
- Påhlman, I.L., Larsson, C., Averét, N., Bunoust, O., Boubekour, S., Gustafsson, L., Rigoulet, M.** (2002). Kinetic regulation of the mitochondrial glycerol-3-phosphate dehydrogenase by the external NADH dehydrogenase in *Saccharomyces cerevisiae*. *Journal of Biological Chemistry*, 277(31): 27991-27995. <https://doi.org/10.1074/jbc.M204079200>
- Patole, M.S., Swaroop, A., Ramasarma, T.** (1986). Generation of H₂O₂ in brain mitochondria. *Journal of Neurochemistry*, 47(1), 1-8. <https://doi.org/10.1111/j.1471-4159.1986.tb02823.x>

-
- Rostovtseva, T.K., Bezrukov, S.M., Hoogerheide, D.P.** (2021). Regulation of mitochondrial respiration by VDAC is enhanced by membrane-bound inhibitors with disordered polyanionic C-terminal domains. *International Journal of Molecular Sciences*, 22(14), 7358. <https://doi.org/10.3390/ijms22147358>
- Seltzer, W.K. & McCabe, E.R.** (1984). Subcellular distribution and kinetic properties of soluble and particulate-associated bovine adrenal glycerol kinase. *Molecular and Cellular Biochemistry*, 64(1), 51-61. <https://doi.org/10.1007/BF00420928>
- Wallimann, T., Tokarska-Schlattner, M., Schlattner, U.** (2011). The creatine kinase system and pleiotropic effects of creatine. *Amino Acids*, 40(5), 1271-1296. <https://doi.org/10.1007/s00726-011-0877-3>
- Yang, M. & Brackenbury, W.J.** (2013). Membrane potential and cancer progression. *Frontiers in Physiology*, 4, 185. <https://doi.org/10.3389/fphys.2013.00185>
- Yu, H.G., McLaughlin, S., Newman, M., Brundage, K., Ammer, A., Martin, K., Coad, J.** (2017). Altering calcium influx for selective destruction of breast tumor. *BMC Cancer*, 17(1), 169. <https://doi.org/10.1186/s12885-017-3168-x>